

6

5

4

3

2

1

TYPE	OUTPUT		POLE	TIME RATING	VOLTAGE V	Hz	SYN. SPEED R.P.M
	HP.	kW.					
AMRKED	400	298.3	4	CONT	2300/4000	60	1800

ENCLOSED VENTILATED VERTICAL SOLID SHAFT TYPE, SQUIRREL CAGE ROTOR  
NEMA WEATHER PROTECTED TYPE 1

NOTE:

1. DIMENSIONS IN INCH
2. FRAME NO.5009
3. F CLASS INSULATION, S.F. 1.15
4. FOR DIRECT COUPLING
5. BEARING SIZE:  
UPPER BEARING: 29330+6028 (INSULATED)  
LOWER BEARING: 6220C3 [UNINSULATED]
6. UPPER BEARING IS INSULATED. ANY METAL CONNECTIONS TO IT MUST BE INSULATED.
7. LUBRICATION:  
UPPER BEARING USE OIL.  
OIL VISCOSITY: ISO VG68 [300 SSU/100°F]  
OIL QUANTITY: 1.8 GAL.  
LOWER BEARING USE GREASE. [MOBIL POLYREX EM]
8. ROTATION: COUNTER-CLOCKWISE [VIEW FROM TOP].
9. WITH NON-REVERSE RATCHET MECHANISM.
10. APPROXIMATE WEIGHT: 3820
11. DOWNTHRUST: 30,900 LBS (L10-8800HRS)
12. REED FREQUENCY: 30 HZ
13. SPACE HEATER RATED AT 120 VOLT, SINGLE PHASE, 200 WATTS, LEADS TERMINATE IN MAIN LEAD BOX.

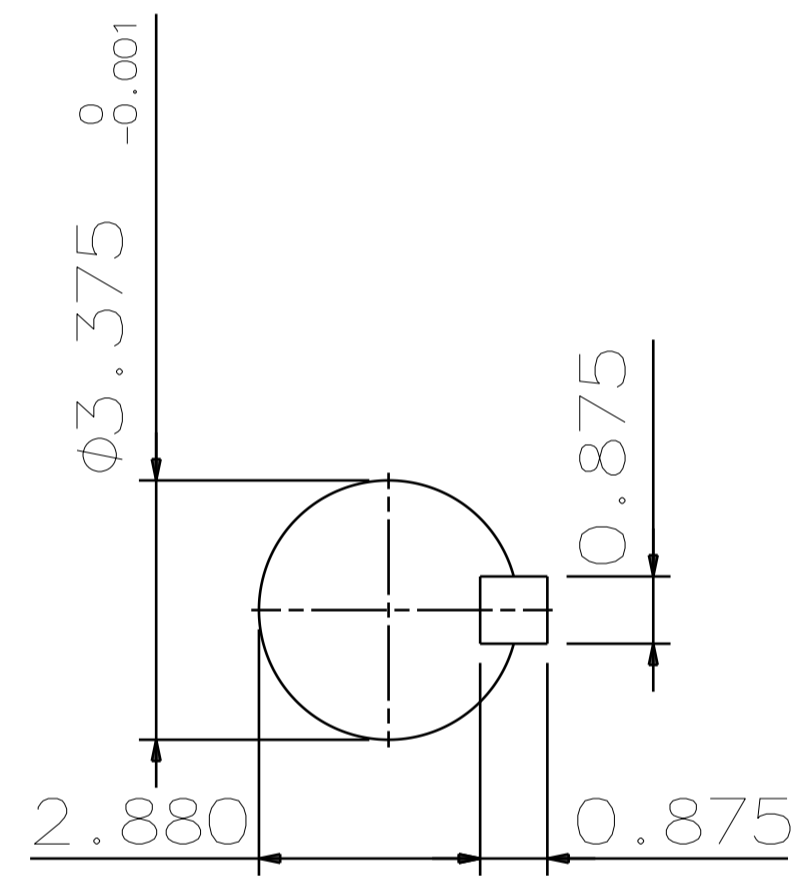
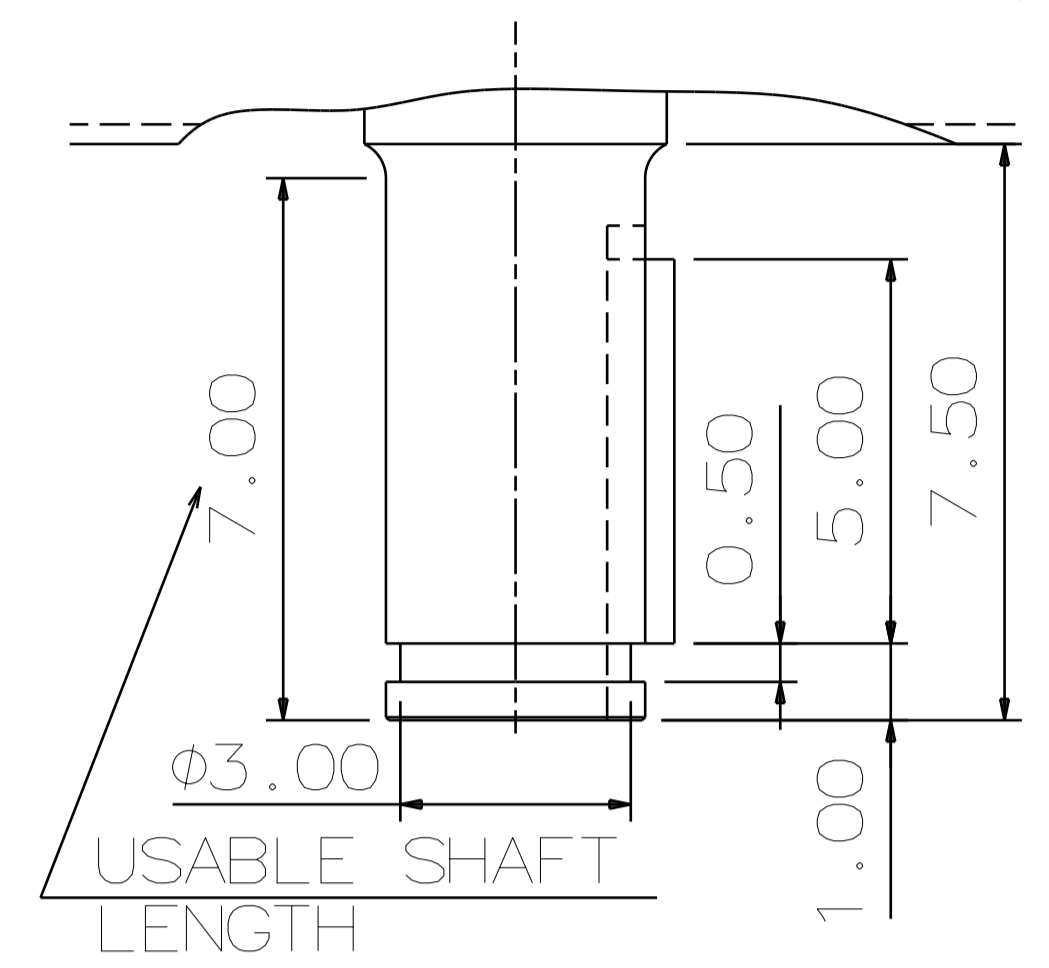

SHAFT END  
(ENLARGED VIEW)

- (A) OIL FILLER [UPPER BEARING]
- (B) OIL GAUGE [UPPER BEARING]
- (C) OIL DRAIN [UPPER BEARING]
- (D) GREASE INLET [LOWER BEARING]
- (E) GREASE DISCHARGER [LOWER BEARING]
- (F) 4~M16 VERTICAL JACKING HOLES, 90°APART IN MOTOR BASE.
- (G) M10 TAPPED GROUNDING ON FRAME, WITH ONE GROUNDING STUDS & [R38-10] TERMINAL LOCATED AS SHOWN.

CENTER OF GRAVITY

PRIMARY T-BOX  
(NPT4")

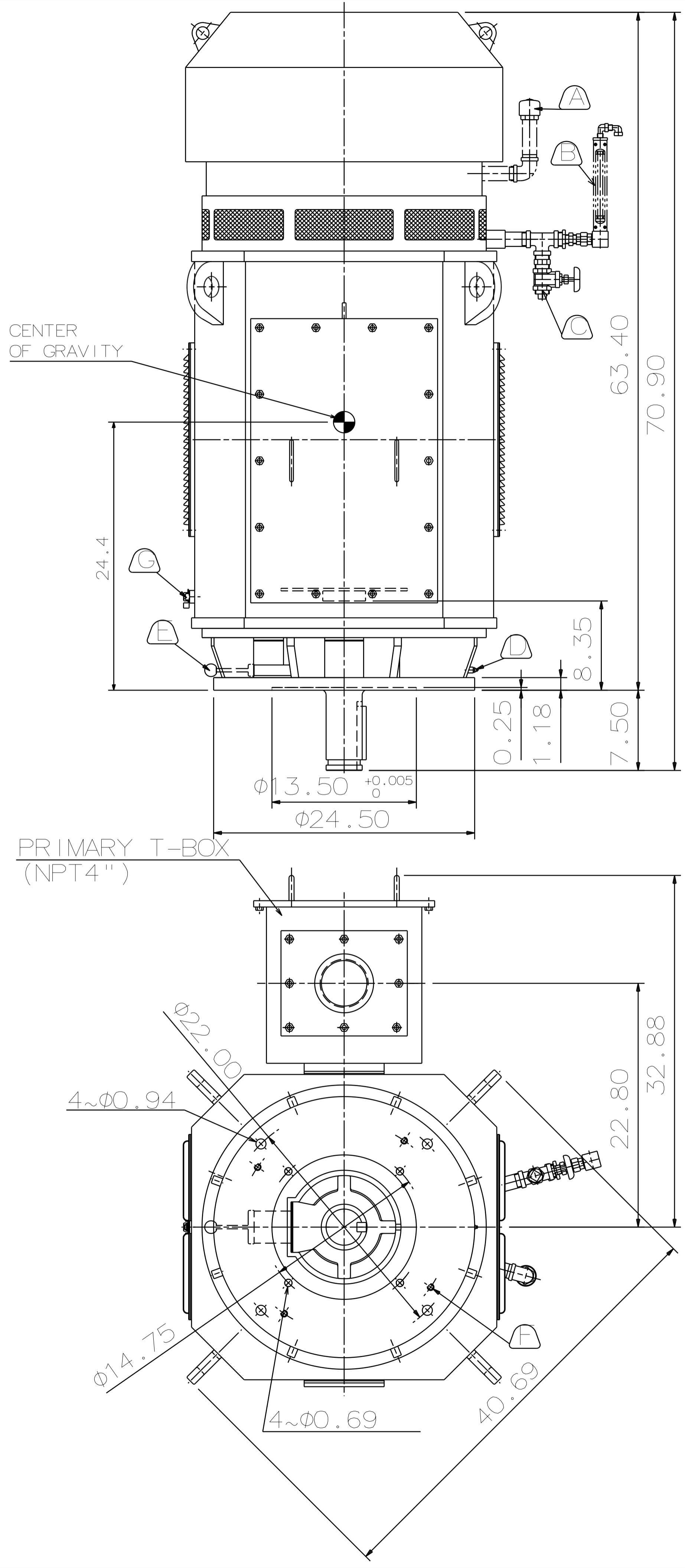

DATE	DEC 08 2016	OUTLINE DIMENSIONS	
	VSKP4004	3-PHASE INDUCTION MOTOR	
DWG NO.	4B040L491	REV:00	

DWN.	Y. YANG	JUN.02.2015
CHKD.	R. LEE	JUN.02.2015
APPD.	C. LIU	JUN.02.2015



6

5

4

3

2

1